

## MAZDA 3 2004-2007

- 1 Disconnect the negative battery terminal to prevent an accidental short circuit.
- 2 Unclip and remove display trim panel above radio. **Tip:** Open glove box and start in middle of panel working towards drivers side first because last connection on far passenger side is a hook. (Figure A)
- 3 Remove (2) Phillips screws exposed at top of radio then unclip and remove radio. **Note:** Display is attached to radio brackets and will be removed at same time as radio. (Figure B)
- 4 Remove (2) Phillips screws on back of display trim panel securing display trim then unclip and remove. (Figure C)

*Continue to display/pocket assembly.*

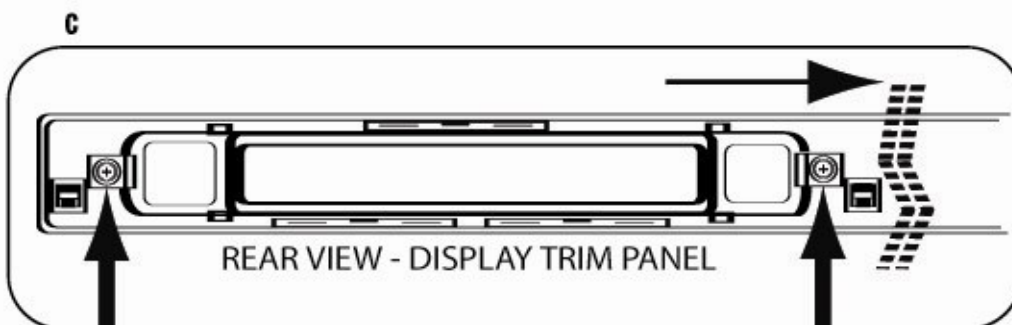
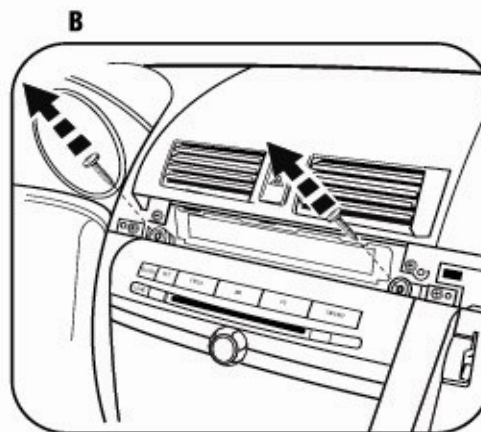
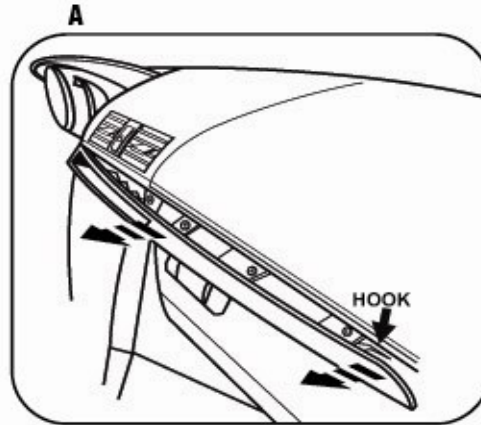

# www.1999.gr

## **DISPLAY BRACKETS/POCKET ASSEMBLY**

### **MAZDA 3 2004-2007**

#### **AUTOMATIC CLIMATE CONTROL VEHICLES**

- 1 Using the factory hardware attach the display retention brackets to the display unit.
- 2 Remove the (2) Phillips screws in the sub dash. (Figure A)
- 3 Secure the display unit into the sub dash using the screws removed in the previous step.

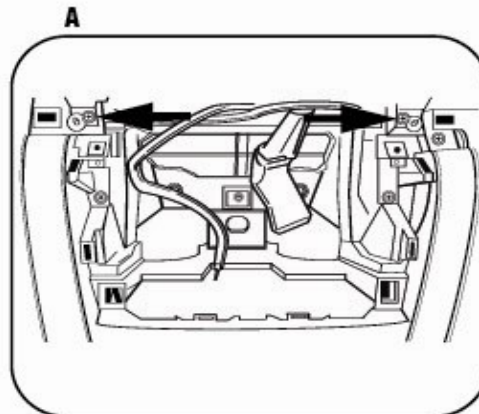

#### **MANUAL CLIMATE CONTROL VEHICLES**

- 1 Using the (2) Phillips screws removed in step 4 of Dash Disassembly secure the display replacement pocket to the back of the display trim panel. (Figure B)

*Continue to kit assembly.*

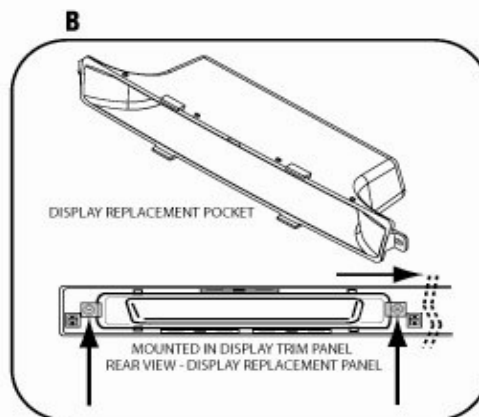

# www.1999.gr

## DOUBLE DIN RADIO PROVISION

*\*Note: Refer also to the instructions included with the aftermarket radio.*

**1** Snap the Double DIN brackets to the inside edge of the radio housing. (Figure A)

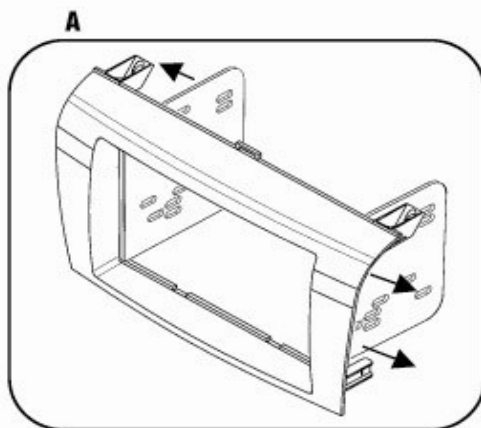

**2** Slide the Double DIN radio into the bracket/radio housing assembly and secure the radio to the assembly using the screws supplied with the radio. Snap the trim plate onto the front of the radio housing. (Figure B)

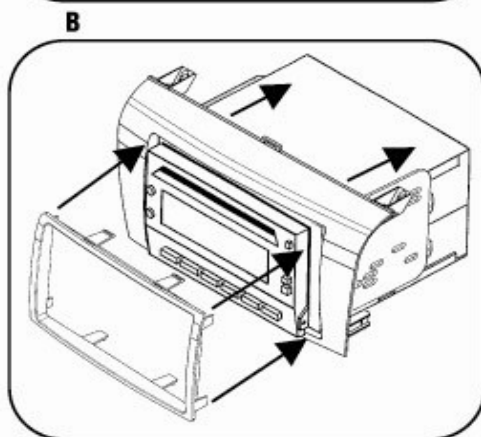

*Continue to final assembly.*

